

# KOP-GRID®

## Tapered Grid Couplings

**INTERCHANGEABLE  
WITH OTHER TAPERED  
GRID COUPLINGS**

---

**TAPERED,  
SHOT PEENED GRIDS  
QUICK, EASY  
INSTALLATION  
LOW MAINTENANCE**

---

**FOR:  
PETROCHEMICAL  
AND REFINING  
MATERIAL HANDLING  
PULP AND PAPER  
FOOD AND TEXTILE  
GENERAL PURPOSE**

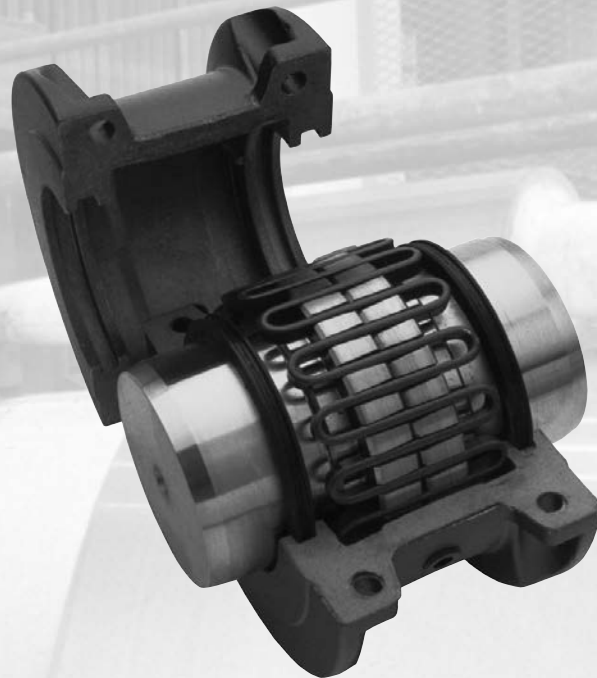

### Index:

	Page
<b>HOW TO ORDER</b> .....	181, 184
Technical Advantages.....	178 - 179
Service Factors .....	180
Interchange Chart .....	181
Selection Procedure .....	181
T10 and T20 Standard Couplings .....	182 - 184
Engineering Data .....	185

## TECHNICAL ADVANTAGES



### TORSIONAL DAMPING

The grid design functions as a resilient coupling by damping torsional vibration and cushioning shock loads, resulting in reduced vibration at the output end of the coupling. Peak loading is reduced, for smooth torque transmission, to help protect connected equipment from potentially damaging vibratory loads.

### OVERLOAD PROTECTION

A second function of the grid design is that it can act much like a protective overload shear device. During an extreme overload, the grid can shear, reducing the possibility of damage to expensive machinery and equipment.

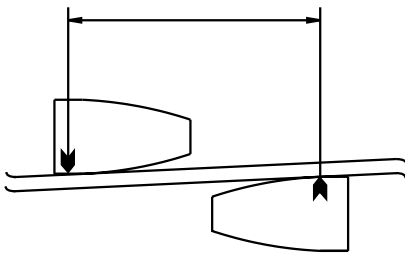

### Light Load

The outer edges of the grid contact the hub tapered teeth for light loads, leaving a long span to bear the load variations and still compensate for misalignment.

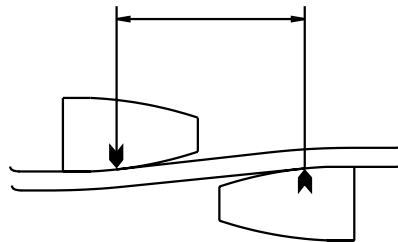

### Normal Load

The grid is free to flex and dampen shock loads, even as the load increases. The span between the support ends shortens with increasing load, however the grid is still free to flex, cushioning shock and compensating for misalignment.

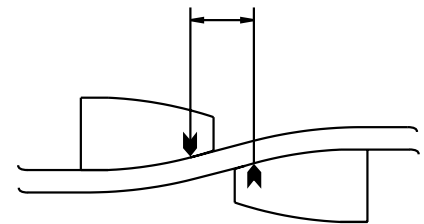

### Shock Load

The KOP-GRID® coupling when under extreme loads, transmits the full load directly to driven equipment with the entire grid in full contact with the hub tapered teeth. The coupling is flexible within its rated capacity.

KOP-GRID® tapered grid couplings are your best choice to protect your investment in expensive driving and driven equipment from misalignment, shock loads and vibration, while accommodating reasonable shaft end float.

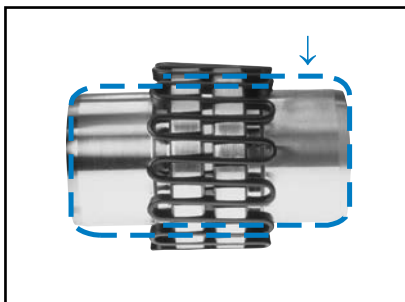

### Offset (Parallel)

Movement of the grid in the hub grooves accommodates parallel misalignment while dampening shock and vibration.

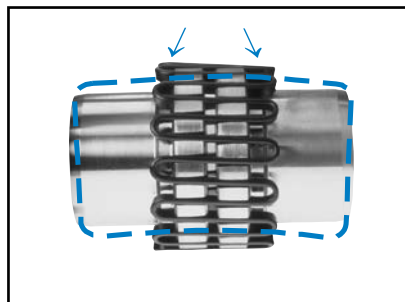

### Angular

With angular misalignment, the grid/groove design permits a rocking and sliding action of grid and hubs without loss of power through the resilient grid.

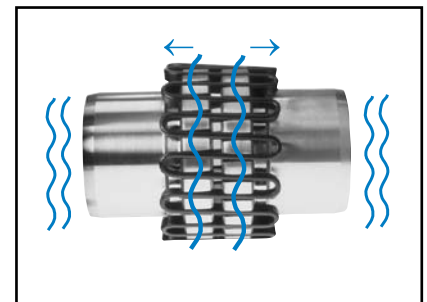

### End Float (Axial)

End float is permitted for both driving and driven shafts because the grid slides freely in the lubricated grooves.

### T10



### T10 WITH HORIZONTAL SPLIT COVERS

Suited for multipurpose industrial applications

Typical Applications:

- Pulp Processing Machinery
- Agitators and Aerators
- Wood Grinders, Chippers
- Conveyors and Crushers
- Steel and Aluminum shaping
- Textile and Food Machinery

Interchangeable with other tapered grid couplings

Horizontally split, aluminum alloy cover

Easy installation and access to tapered grids

Easy assembly in confined spaces

Absorbs moderate shock and vibratory loads. Torsionally flexible

Suitable for reversing service

Socket head capscrews and self-locking nuts

Steel hubs — straight bores or standard bushings

### T20 WITH VERTICAL SPLIT COVERS

Designed for higher speed applications

Typical Applications:

- Food and Grain Process Equipment
- Chemical Process Machinery
- Screw Compressors and Vacuum Pumps
- Fans, Blowers and Dryers
- Gearbox Input Shafts

Interchangeable with other tapered grid couplings

Vertically split, corrosion resistant steel covers.

Grade 8 hex head fasteners

Torsionally flexible

Steel hubs — straight bores or standard bushings

### T20



## SERVICE FACTORS

Values listed are intended only as a general guide, and are typical of usual service requirements. For systems which frequently utilize the peak torque capability of the power source, verify that the magnitude of this peak torque does not exceed the 1.0 Service Factor Rating of the coupling selected. Applications which involve extreme repetitive shock or high-energy load absorption characteristics should be referred — with full particulars — to KOP-FLEX.

Values contained in the table are to be applied to smooth power sources such as electric motors and steam turbines. For drives involving internal combustion engines of four or five cylinders, add 1.0 to the values listed; for six or more cylinders, add 0.5 to the values listed. For systems utilizing AC or DC Mill Motors as the prime mover, refer to Note (1).

**CAUTION!** All people moving plus overhead crane applications must be referred to engineering.

Application	Typical Service Factor
<b>AGITATORS</b>	
Pure Liquids .....	1.0
Liquids & Solids .....	1.25
Liquids — Variable Density .....	1.25
<b>BLOWERS</b>	
Centrifugal .....	1.0
Lobe .....	1.5
Vane .....	1.25
<b>BRIQUETTE MACHINES</b> .....	2.0
<b>CAR PULLERS</b> — Intermittent Duty .....	1.5
<b>COMPRESSORS</b>	
Centrifugal .....	1.0
Centriaial .....	1.25
Lobe .....	1.5
Reciprocating — Multi-Cylinder .....	2.0
<b>CONVEYORS — LIGHT DUTY</b>	
<b>UNIFORMLY FED</b>	
Apron, Bucket, Chain, Flight, Screw .....	1.25
Assembly, Belt .....	1.0
Oven .....	1.5
<b>CONVEYORS — HEAVY DUTY</b>	
<b>NOT UNIFORMLY FED</b>	
Apron, Bucket, Chain, Flight, Oven .....	1.5
Assembly, Belt .....	1.25
Reciprocating, Shaker .....	2.5
<b>CRANES AND HOISTS (NOTE 1 and 2)</b>	
Main hoists, Reversing .....	2.5
Skip Hoists, Trolley & Bridge Drives .....	2.0
Slope .....	2.0
<b>CRUSHERS</b>	
Ore, Stone .....	3.0
<b>DREDGES</b>	
Cable Reels .....	1.75
Conveyors .....	1.5
Cutter Head Jig Drives .....	2.5
Maneuvering Winches .....	1.75
Pumps .....	1.75
Screen Drives .....	1.75
Stackers .....	1.75
Utility Winches .....	1.5
<b>ELEVATORS (NOTE 2)</b>	
Bucket .....	1.75
Centrifugal & Gravity Discharge .....	1.5
Escalators .....	1.5
Freight .....	2.5
<b>FANS</b>	
Centrifugal .....	1.0
Cooling Towers .....	1.5
Forced Draft .....	1.5
Induced Draft without Damper Control .....	2.0
<b>FEEDERS</b>	
Apron, Belt, Disc, Screw .....	1.25
Reciprocating .....	2.5

Application	Typical Service Factor
<b>GENERATORS</b> —	
(Not Welding) .....	1.0
<b>HAMMER MILLS</b> .....	2.0
<b>LAUNDRY WASHERS</b> —	
Reversing .....	2.0
<b>LAUNDRY TUMBLERS</b> .....	2.0
<b>LINE SHAFT</b> .....	1.5
<b>LUMBER INDUSTRY</b>	
Barkers — Drum Type .....	2.0
Edger Feed .....	2.0
Live Rolls .....	2.0
Log Haul — Incline .....	2.0
Log Haul — Well type .....	2.0
Off Bearing Rolls .....	2.0
Planer Feed Chains .....	1.75
Planer Floor Chains .....	1.75
Planer Tilting Hoist .....	1.75
Slab Conveyor .....	1.5
Sorting Table .....	1.5
Trimmer Feed .....	1.75
<b>MARINE PROPULSION</b>	
Main Drives .....	2.0
<b>MACHINE TOOLS</b>	
Bending Roll .....	2.0
Plate Planer .....	1.5
Punch Press — Gear Driven .....	2.0
Tapping Machines .....	2.5
Other Machine Tools	
Main Drives .....	1.5
Auxiliary Drives .....	1.25
<b>METAL MILLS</b>	
Draw Bench — Carriage .....	2.0
Draw Bench — Main Drive .....	2.0
Forming Machines .....	2.0
Slitters .....	1.5
Table Conveyors	
Non-Reversing .....	2.25
Reversing .....	2.5
Wire Drawing & Flattening Machine .....	2.0
Wire Winding Machine .....	1.75
<b>METAL ROLLING MILLS (NOTE 1)</b>	
Blooming Mills .....	*
Coilers, hot mill .....	2.0
Coilers, cold mill .....	1.25
Cold Mills .....	2.0
Cooling Beds .....	1.75
Door Openers .....	2.0
Draw Benches .....	2.0
Edger Drives .....	1.75
Feed Rolls, Reversing Mills .....	3.5
Furnace Pushers .....	2.5
Hot Mills .....	3.0
Ingot Cars .....	2.5
Kick-outs .....	2.5
Manipulators .....	3.0
Merchant Mills .....	3.0
Piercers .....	3.0
Pusher Rams .....	2.5
Reel Drives .....	1.75
Reel Drums .....	2.0
Reelers .....	3.0
Rod and Bar Mills .....	1.5
Roughing Mill Delivery Table .....	3.0
Runout Tables	
Reversing .....	3.0
Non-Reversing .....	2.0
Saws, hot & cold .....	2.5
Screwdown Drives .....	3.0
Skelp Mills .....	3.0
Slitters .....	3.0
Slabbing Mills .....	3.0
Soaking Pit Cover Drives .....	3.0
Straighteners .....	2.5
Tables, transfer & runout .....	2.0
Thrust Block .....	3.0
Traction Drive .....	3.0
Tube Conveyor Rolls .....	2.5
Unscramblers .....	2.5
Wire Drawing .....	1.5
<b>MILLS, ROTARY TYPE</b>	
Ball .....	2.25
Dryers & Coolers .....	2.0
Hammer .....	1.75
Kilns .....	2.0

Application	Typical Service Factor
Pebble & Rod .....	2.0
Pug .....	1.75
Tumbling Barrels .....	2.0
<b>MIXERS</b>	
Concrete Mixers .....	1.75
Drum Type .....	1.5
<b>OIL INDUSTRY</b>	
Chillers .....	1.25
Paraffin Filter Press .....	1.75
<b>PAPER MILLS</b>	
Barker Auxiliaries, Hydraulic .....	2.0
Barker, Mechanical .....	2.0
Barking Drum Spur Gear Only .....	2.25
Beater & Pulper .....	1.75
Bleacher .....	1.0
Calenders .....	2.0
Chippers .....	2.5
Coaters .....	1.0
Converting Machines, except Cutters, Platers .....	1.5
Couch Roll .....	1.75
Cutters, Platers .....	2.0
Cylinders .....	1.75
Disc Refiners .....	1.75
Dryers .....	1.75
Felt Stretcher .....	1.25
Felt Whipper .....	2.0
Jordans .....	1.75
Line Shaft .....	1.5
Log Haul .....	2.0
Pulp Grinder .....	1.75
Press Roll .....	2.0
Reel .....	1.5
Stock Chests .....	1.5
Suction Roll .....	1.75
Washers & Thickeners .....	1.5
Winders .....	1.5
<b>PRINTING PRESSES</b> .....	1.5
<b>PULLERS</b> — Barge Haul .....	2.0
<b>PUMPS</b>	
Centrifugal .....	1.0
Boiler Feed .....	1.5
Reciprocating	
Single Acting	
1 or 2 Cylinders .....	2.25
3 or more Cylinders .....	1.75
Double Acting .....	2.0
Rotary, Gear, Lobe, Vane .....	1.5
<b>RUBBER INDUSTRY</b>	
Mixer — Banbury .....	2.5
Rubber Calendar .....	2.0
Rubber Mill (2 or more) .....	2.25
Sheeter .....	2.0
Tire Building Machines .....	2.5
Tire & Tube Press Openers .....	1.0
Tubers & Strainers .....	2.0
<b>SCREENS</b>	
Air Washing .....	1.0
Grizzly .....	2.0
Rotary — Stone or Gravel .....	1.5
Traveling Water Intake .....	1.25
Vibrating .....	2.5
<b>SEWAGE DISPOSAL EQUIPMENT</b>	
Bar Screens .....	1.25
Chemical Feeders .....	1.25
Collectors, Circuline or Straightline .....	1.25
Dewatering Screens .....	1.25
Grit Collectors .....	1.25
Scum Breakers .....	1.25
Slow or Rapid Mixers .....	1.25
Sludge Collectors .....	1.25
Thickeners .....	1.25
Vacuum Filters .....	1.25
<b>STEERING GEAR</b> .....	1.0
<b>STOKERS</b> .....	1.0
<b>WINCH</b> .....	1.5
<b>WINDLASS</b> .....	1.75

\* Refer to KOP-FLEX

### NOTES

- (1) Maximum Torque at the coupling must not exceed Rated Torque of the coupling.
- (2) Check local and industrial safety codes.

## SELECTION PROCEDURE

### 1. COUPLING TYPE:

Select the appropriate KOP-GRID® coupling type for your application. See page 179 for coupling types.

### 2. COUPLING SIZE:

**Step 1:** Determine the proper service factor from page 180.

**Step 2:** Calculate the required HP/100 RPM, using the HP rating of the drive and the coupling speed (RPM) as shown below:

$$\frac{\text{HP} \times \text{SERVICE FACTOR} \times 100}{\text{RPM}} = \text{HP}/100 \text{ RPM}$$

**Step 3:** Select the coupling size having a rating sufficient to handle the required HP/100 RPM at the appropriate service factor.

**Step 4:** Verify that the actual coupling speed (RPM) is equal to or less than the maximum allowable speed rating of the coupling.

**Step 5:** Verify that the maximum bore of the coupling selected is equal to or larger than either of the equipment shafts.

**Step 6:** Check the overall dimensions to ensure coupling will not interfere with the coupling guard, piping, or the equipment housings and that it will fit the required shaft separation.

### KOP-GRID® Coupling Interchange Guide

KOP-GRID® couplings are interchangeable with other tapered grid couplings, component by component • hubs, grids, seals, and cover assembly

KOP-GRID	FALK*	DODGE*	LOVEJOY*
1020T	1020T	1020T	2020
1030T	1030T	1030T	2030
1040T	1040T	1040T	2040
1050T	1050T	1050T	2050
1060T	1060T	1060T	2060
1070T	1070T	1070T	2070
1080T	1080T	1080T	2080
1090T	1090T	1090T	2090
1100T	1100T	1100T	2100
1110T	1110T	1110T	2110
1120T	1120T	1120T	2120
1130T	1130T	1130T	2130
1140T	1140T	1140T	2140

Coupling Types	KOP-GRID	FALK*	DODGE*	LOVEJOY*
Horizontally Split Cover	T10	T10	T10	H
Vertically Split Cover	T20	T20	T20	V

### PART NUMBER EXPLANATION Complete Rough Bore Coupling

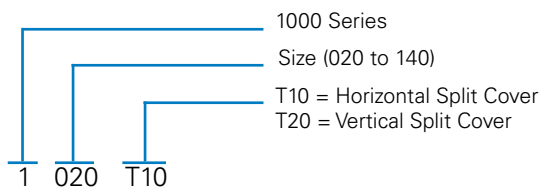

### Coupling Parts

- Description
- HUB = Rough Bore Hub
  - HUBxBORE = Finished Bore Hub
  - HUBx(Bushing Size) = Hubs for Split Taper Bushing
  - GRID = Tapered Grid
  - T10 CGA = Cover and Grid Ass'y Horizontal
  - T20 CGA = Cover and Grid Ass'y Vertical
  - T10 Cover = Horizontal Split Cover
  - T20 Cover = Vertical Split Cover
  - T10 AK = Horizontal Cover Accessory Kit
  - T20 AK = Vertical Cover Accessory Kit
  - SHUB = Shaft Hub
  - SHUBx(Bushing Size) = Shaft Hub for Split Taper Bushing

ex. 1020 HUBx5/8

\* The following are believed to be the trademarks and/or trade names of their respective owners, and are not owned or controlled by Regal Power Transmission Solutions. Dodge: Reliance Electric Company; Falk: Rexnord Industries LLC; Lovejoy: Lovejoy, Inc.

## T10 WITH HORIZONTAL SPLIT COVERS

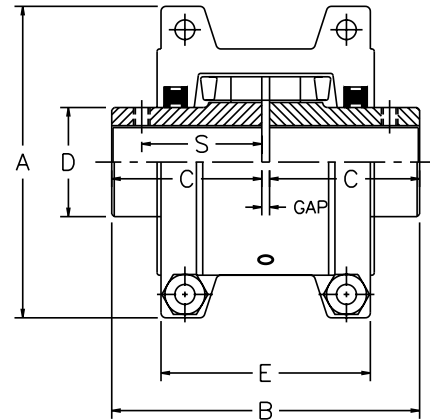
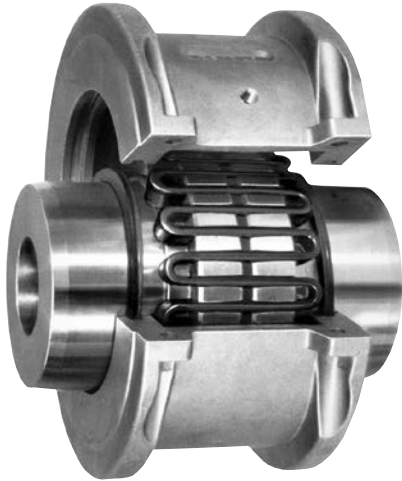

## T20 WITH VERTICAL SPLIT COVERS

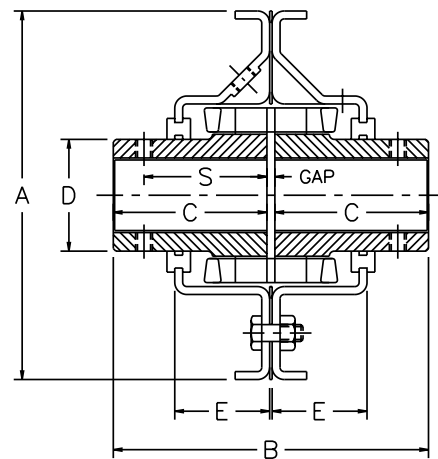

## T10 & T20 WITH BROWNING SPLIT TAPER® BUSHING

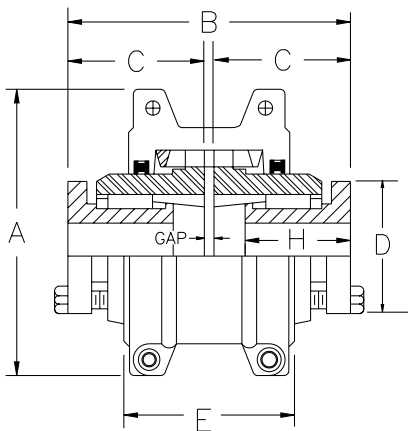

**T10 W/BUSHINGS**

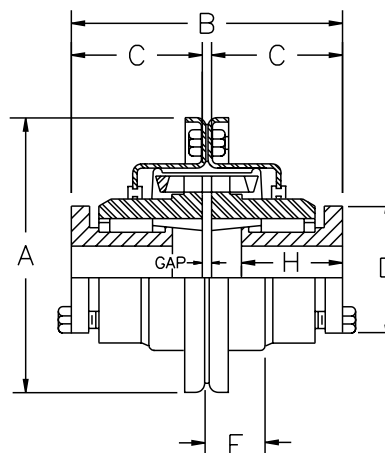

**T20 W/BUSHINGS**

**TABLE NO. 1 SPECIFICATIONS — KOP-GRID® T10 WITH HORIZONTAL SPLIT COVERS**

Coupling Size	HP per 100 RPM	Torque Rating (lb.-in.)	Maximum Speed RPM	Maximum Bore (Square Key)	Cplg. Wt. With No Bore - lb.	Dimensions - Inches						
						A	B	C	D	E	S	Gap
1020	0.68	422	4500	1.125	4.2	4.00	3.88	1.88	1.56	2.62	1.36	.125
1030	1.93	1200	4500	1.375	5.7	4.38	3.88	1.88	1.94	2.69	1.54	.125
1040	3.22	2000	4500	1.625	7.5	4.62	4.12	2.00	2.25	2.75	1.58	.125
1050	5.63	3500	4500	1.875	12	5.44	4.88	2.38	2.62	3.12	1.75	.125
1060	8.85	5500	4350	2.125	16	5.94	5.12	2.50	3.00	3.62	2.06	.125
1070	13	8000	4125	2.500	22	6.38	6.12	3.00	3.44	3.75	2.12	.125
1080	27	16500	3600	3.000	40	7.64	7.12	3.50	4.12	4.57	2.54	.125
1090	48	30000	3600	3.500	55	8.38	7.88	3.88	4.88	4.81	2.81	.125
1100	81	50500	2440	4.000	93	9.84	9.69	4.75	5.59	6.12	-	.188
1110	121	75000	2250	4.500	119	10.62	10.19	5.00	6.31	6.36	-	.188
1120	177	110000	2025	5.000	179	12.12	12.00	5.88	7.06	7.54	-	.250
1130	257	160000	1800	6.000	267	13.62	13.00	6.38	8.56	7.69	-	.250
1140	370	230000	1650	7.250	393	15.12	14.65	7.19	10.00	7.91	-	.250

**TABLE NO. 2 SPECIFICATIONS — KOP-GRID® T20 WITH VERTICAL SPLIT COVERS**

Coupling Size	HP per 100 RPM	Torque Rating (lb.-in.)	Maximum Speed RPM	Maximum Bore (Square Key)	Cplg. Wt. With No Bore - lb.	Dimensions - Inches						
						A	B	C	D	E	S	Gap
1020	0.68	422	6000	1.125	4.3	4.38	3.88	1.88	1.56	0.95	1.36	.125
1030	1.93	1200	6000	1.375	5.7	4.75	3.88	1.88	1.94	0.98	1.54	.125
1040	3.22	2000	6000	1.625	7.4	5.06	4.12	2.00	2.25	1.00	1.58	.125
1050	5.63	3500	6000	1.875	12	5.81	4.88	2.38	2.62	1.22	1.75	.125
1060	8.85	5500	6000	2.125	16	6.38	5.12	2.50	3.00	1.28	2.06	.125
1070	13	8000	5500	2.500	23	6.81	6.12	3.00	3.44	1.33	2.12	.125
1080	27	16500	4750	3.000	39	7.88	7.12	3.50	4.12	1.75	2.54	.125
1090	48	30000	4000	3.500	56	9.12	7.88	3.88	4.88	1.88	2.81	.125
1100	81	50500	3250	4.000	93	10.50	9.69	4.75	5.59	2.36	-	.188
1110	121	75000	3000	4.500	120	11.25	10.19	5.00	6.31	2.53	-	.188
1120	177	110000	2700	5.000	180	12.56	12.00	5.88	7.06	2.88	-	.250
1130	257	160000	2400	6.000	270	14.88	13.00	6.38	8.56	2.96	-	.250
1140	370	230000	2200	7.250	397	16.38	14.65	7.19	10.00	3.08	-	.250

**TABLE NO. 3 SPECIFICATIONS — KOP-GRID® T10 & T20 COUPLINGS FOR BROWNING SPLIT TAPER® BUSHINGS**

Coupling Size	H.P. per 100 RPM	Torque Rating (lb.-in.)	Bushing	Bore Range	Wt. Less Bushing (lb.)	Dimensions - Inches								Gap
						A		B	C	D	E		H	
						T10 Cover	T20 Cover				T10 Cover	T20 Cover		
1040	1.98	1250	G	.375-1.0	6.3	4.62	5.06	4.38	1.94	2.00	2.75	1.00	1.00	.125
1050	4.19	2640	H	.375-1.5	10.0	5.44	5.81	4.88	2.19	2.50	3.12	1.25	1.25	.125
1060	8.71	5500	P1	.5-1.75	13.3	5.94	6.38	5.88	2.63	3.00	3.62	1.25	1.94	.125
1070	13	8000	P1	.5-1.75	18.7	6.38	6.86	5.88	2.63	3.00	3.75	1.38	1.94	.125
1080	26	16500	Q1	.75-2.688	30.6	7.64	7.88	7.19	3.25	4.13	4.56	1.75	2.50	.125
1090	33	20500	Q1	.75-2.688	44.6	8.38	9.12	7.44	3.38	4.13	4.81	1.88	2.50	.125
1100	65	40900	R1	1.125-3.75	70	9.88	10.50	9.00	4.12	5.38	6.12	2.38	2.88	.188
1110	65	40900	R1	1.125-3.75	94	10.62	11.25	9.25	4.25	5.38	6.36	2.50	2.88	.188
1120	127	79800	S1	1.688-4.25	140	12.12	12.56	11.13	5.06	6.38	7.55	3.00	4.38	.250
1130	254	160000	U0	3.25-5.50	199	13.62	14.88	11.56	5.19	8.38	7.69	3.00	4.94	.250
1140	297	187000	U0	3.25-5.50	294	15.12	16.38	11.19	5.31	8.38	7.92	3.12	4.94	.250

Note: See Table 1 and 2 for maximum speeds.

## HOW TO ORDER T10 & T20 COUPLINGS

**TABLE NO. 4 KOP-GRID® COUPLINGS — HUBS, GRID, COVER, SEAL AND FASTENER KITS**

Cplg. Size	Complete Rough Bore Couplings ①		Hubs					T10 Horizontal			T20 Vertical		
	T10 Horizontal Split Cover	T20 Vertical Split Cover	Grid Hub No Bore	Finished Bore and Bored to Size ②	Grid Hub Bushed	Bush-ing	Tapered Grid Kit	Cover and Grid Assembly	Cover Kit	Accessory Kit	Cover and Grid Assembly	Cover Kit	Accessory Kit
1020	1020T10	1020T20	1020 HUB	1020 HUB x Bore	—	—	1020 GRID	1020T10 CGA	1020T10 COVER	1020T10 AK	1020T20 CGA	1020T20 COVER	1020T20 AK
1030	1030T10	1030T20	1030 HUB	1030 HUB x Bore	—	—	1030 GRID	1030T10 CGA	1030T10 COVER	1030T10 AK	1030T20 CGA	1030T20 COVER	1030T20 AK
1040	1040T10	1040T20	1040 HUB	1040 HUB x Bore	1040 HUBXG	G	1040 GRID	1040T10 CGA	1040T10 COVER	1040T10 AK	1040T20 CGA	1040T20 COVER	1040T20 AK
1050	1050T10	1050T20	1050 HUB	1050 HUB x Bore	1050 HUBXH	H	1050 GRID	1050T10 CGA	1050T10 COVER	1050T10 AK	1050T20 CGA	1050T20 COVER	1050T20 AK
1060	1060T10	1060T20	1060 HUB	1060 HUB x Bore	1060 HUBXP	P1	1060 GRID	1060T10 CGA	1060T10 COVER	1060T10 AK	1060T20 CGA	1060T20 COVER	1060T20 AK
1070	1070T10	1070T20	1070 HUB	1070 HUB x Bore	1070 HUBXP	P1	1070 GRID	1070T10 CGA	1070T10 COVER	1070T10 AK	1070T20 CGA	1070T20 COVER	1070T20 AK
1080	1080T10	1080T20	1080 HUB	1080 HUB x Bore	1080 HUBXQ	Q1	1080 GRID	1080T10 CGA	1080T10 COVER	1080T10 AK	1080T20 CGA	1080T20 COVER	1080T20 AK
1090	1090T10	1090T20	1090 HUB	1090 HUB x Bore	1090 HUBXQ	Q1	1090 GRID	1090T10 CGA	1090T10 COVER	1090T10 AK	1090T20 CGA	1090T20 COVER	1090T20 AK
1100	1100T10	1100T20	1100 HUB	1100 HUB x Bore	1100 HUBXR	R1	1100 GRID	1100T10 CGA	1100T10 COVER	1100T10 AK	1100T20 CGA	1100T20 COVER	1100T20 AK
1110	1110T10	1110T20	1110 HUB	1110 HUB x Bore	1110 HUBXR	R1	1110 GRID	1110T10 CGA	1110T10 COVER	1110T10 AK	1110T20 CGA	1110T20 COVER	1110T20 AK
1120	1120T10	1120T20	1120 HUB	1120 HUB x Bore	1120 HUBXS	S1	1120 GRID	1120T10 CGA	1120T10 COVER	1120T10 AK	1120T20 CGA	1120T20 COVER	1120T20 AK
1130	1130T10	1130T20	1130 HUB	1130 HUB x Bore	1130 HUBXU	U0	1130 GRID	1130T10 CGA	1130T10 COVER	1130T10 AK	1130T20 CGA	1130T20 COVER	1130T20 AK
1140	1140T10	1140T20	1140 HUB	1140 HUB x Bore	1140 HUBXU	U0	1140 GRID	1140T10 CGA	1140T10 COVER	1140T10 AK	1140T20 CGA	1140T20 COVER	1140T20 AK

- ① To order complete Rough Bore Couplings, specify by Part Number only, for example "1020T10"; Rough Bore Hubs, and T10 Cover and Grid Assembly is included.
- ② To order a Coupling with Finished Bore or Bored to Size Hubs, order two hubs, one Cover and Grid Assembly. Specify Hub Part Number x Bore Size, for example "1020HUBx5/8". If the bore size indicated is shown in Table No. 4, above, then the hub is a Standard Finished Bore Hub; otherwise a Rough Bore Hub must be rebored.
- ③ To order a Coupling with Split Taper Bushings, order two Bushed Hubs and two appropriate Bushings, one Cover and Grid Assembly.
- ④ Cover Kits include Seal and Fastener Sets. The Assembly Kits shown are for REPLACEMENT ONLY.

**Coupling Greases**  
 KOP-FLEX offers greases specifically designed for use in coupling applications. For proper lubrication and long service life, use KSG Standard Coupling Grease, or KHP High Performance Coupling Grease. See pages 170 -172 for detailed specifications.

**TABLE NO. 5 STANDARD CLEARANCE BORED HUBS WITH SETSCREWS**

Hub Part No.*	Standard Bores (Inches)																					
	1/2	5/8	3/4	7/8	1	1 1/8	1 1/4	1 3/8	1 1/2	1 5/8	1 3/4	1 7/8	2	2 1/8	2 1/4	2 3/8	2 1/2	2 5/8	2 3/4	2 7/8	3	3 3/8
1020H	X	X	X	X	X	X																
1030H		X	X	X	X	X	X	X														
1040H				X	X	X	X	X	X	X												
1050H						X	X	X	X	X	X											
1060H								X	X	X	X	X	X	X								
1070H										X	X	X	X	X	X							
1080H											X	X	X	X	X	X	X					
1090H													X	X		X	X		X	X	X	X

\*Complete Hub Part Number by adding Bore Size. Other bores are available by boring Rough Bore Hubs.  
 NOTE — Hub Numbers 1020 HUB through 1190 HUB have clearance fit bores with setscrew over Keyway.  
 — Hub Numbers 1100 HUB through 1140 HUB have interference fit bores with no Setscrew.



### TYPE T10 & T20 GRID HUB BORE CAPACITY WITH SQUARE AND RECTANGULAR KEYS ① ② ③

Size	For One Square Key			For One Rectangular Key					
	Max. Bore (in.)	Y = X		Max. Bore (in.)	Y = X		Max. Bore (in.)	Y = W/2	
		W	X		W	X		W	X
1020	1.125	.250	.125	1.187	.250	.093	1.250	.250	.062
1030	1.375	.312	.156	1.437	.375	.125	1.562	.375	.062
1040	1.625	.375	.187	1.750	.375	.125	1.750	.375	.062
1050	1.875	.500	.250	2.000	.500	.187	2.125	.500	.125
1060	2.125	.500	.250	2.250	.500	.187	2.375	.625	.125
1070	2.500	.625	.312	2.687	.625	.218	2.875	.750	.125
1080	3.000	.750	.375	3.250	.750	.250	3.375	.875	.187
1090	3.500	.875	.437	3.750	.875	.312	3.875	1.000	.250
1100	4.000	1.000	.500	4.250	1.000	.375	4.500	1.000	.250
1110	4.500	1.000	.500	4.625	1.250	.437	5.000	1.250	.250
1120	5.000	1.250	.625	5.375	1.250	.437	5.750	1.500	.250
1130	6.000	1.500	.750	6.500	1.500	.500	6.500	1.500	.250
1140	7.000	1.750	.875	7.250	1.750	.750	7.750	2.000	.500

- ① Size 1020 thru 1090 are furnished with Clearance Fit and one setscrew over the keyway, unless otherwise specified.
- ② Size 1100 thru 1140 are furnished with Interference Fit and no setscrews, unless otherwise specified.
- ③ Standard keyway and bore tolerances (Reference: AGMA/ANSI 9002)

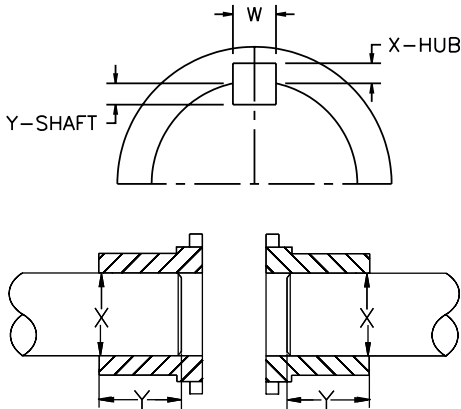

Note: Dimension "Y" (Shaft Keyway Depth) equals one-half of square key. Check key stresses.

### SHAFT ENGAGEMENT

When the distance between the shaft ends is greater than the coupling gap, each shaft must engage the hub by an amount at least equal to the shaft diameter. (Dimension Y must be equal to, or greater than, Dimension x).

### MISALIGNMENT CAPACITY

Size	Recommended Installation Maximum		Maximum Operating		Normal Gap ± 10%	
	Offset (Parallel)	Angular X-Y	Offset (Parallel)	Angular X-Y	T10, T20, T31	T35
1020	0.006	0.003	0.012	0.010	0.125	0.188
1030	0.006	0.003	0.012	0.012	0.125	0.188
1040	0.006	0.003	0.012	0.013	0.125	0.188
1050	0.008	0.004	0.016	0.016	0.125	0.188
1060	0.008	0.005	0.016	0.018	0.125	0.188
1070	0.008	0.005	0.016	0.020	0.125	0.188
1080	0.008	0.006	0.016	0.024	0.125	0.188
1090	0.008	0.007	0.016	0.028	0.125	0.188
1100	0.010	0.008	0.020	0.033	0.188	0.250
1110	0.010	0.009	0.020	0.036	0.188	0.250
1120	0.011	0.010	0.022	0.040	0.250	0.375
1130	0.011	0.012	0.022	0.047	0.250	0.375
1140	0.011	0.013	0.022	0.053	0.250	0.375

